

Model No : CA11D26.11



Features:

- High-density aluminum alloy housing.
- Compact design for easy integration into various tight spaces.
- Multiple beam angles for precise control.
- DeepBlack Anti-Glare Optics for visual comfort.



Normal/RAL series:9002/9006/9011
Custom Colour &Finish

DMX Zigbee DALI Bluetooth APP control CASAMBI TRIAC DIM RoHS CE



Application:

- It's widely used as a decorative lights, and use it as the lights;
- Stage decoration, festival, exhibition, wedding;
- Backlight of signage, channel letters lighting;
- Landscape layout lighting;

Dimensions:

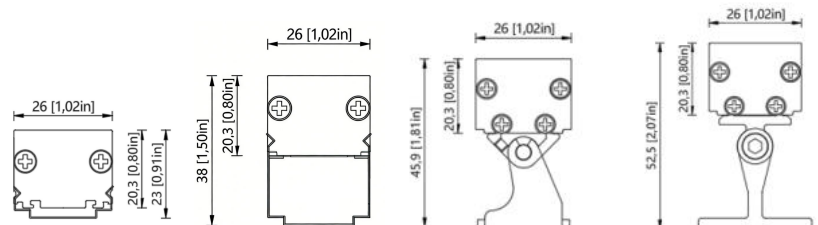
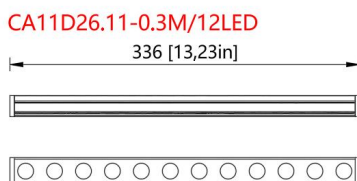
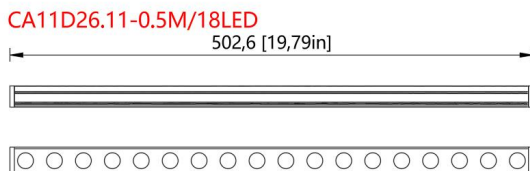
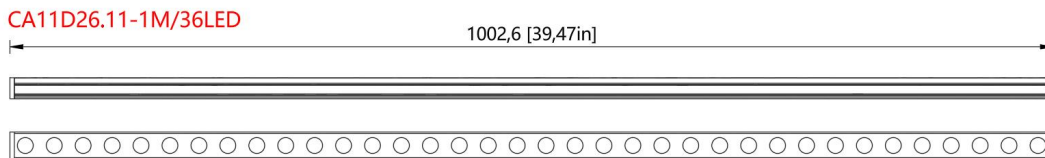

Physical

Housing Material	6063 AviationGrade Aluminum
Lens Material	Tempered glass
End Cap Material	Die cast aluminium
Gasket Material	Silicone
Surface Finish	primer and electrostatically-applied, powder coat paint finish
Weight	/

Electrical and Control

Voltage	DC 24V
Wattage	Max 24W/M
Control	0-10V / DMX / DALI /ON /OFF
Inrush Current (Peak)	Meets NEMA-410 requirements (Based on voltage and control specifications, consult factory for details)

Environmental

Storage Temperature	-40 °C to 85 °C
Start-up Temperature	-40 °C to 50 °C
Operating Temperature	For 32.8 W/m fixtures: -40 °C to 50 °C For 72.18 W/m fixtures, CE Certification: -40 °C to 40 °C
Ingress Protection Rating	IP40 IP65 (It can prevent the low-pressure jet water from invading from any direction, but it does not mean it can be soaked in water for a long time) .For details please consult the factory

Accessories (Order Separately)

Cables	Lumenfacade Leader Cable Lumenfacade Jumper Cable Lumenfacade T-Junction
--------	--

Optional Beam Angle

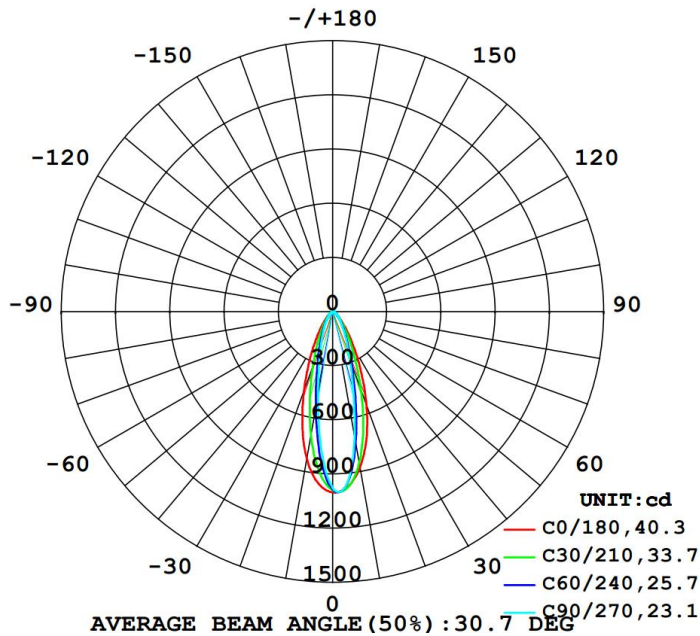

Flux out: 107.5 lm

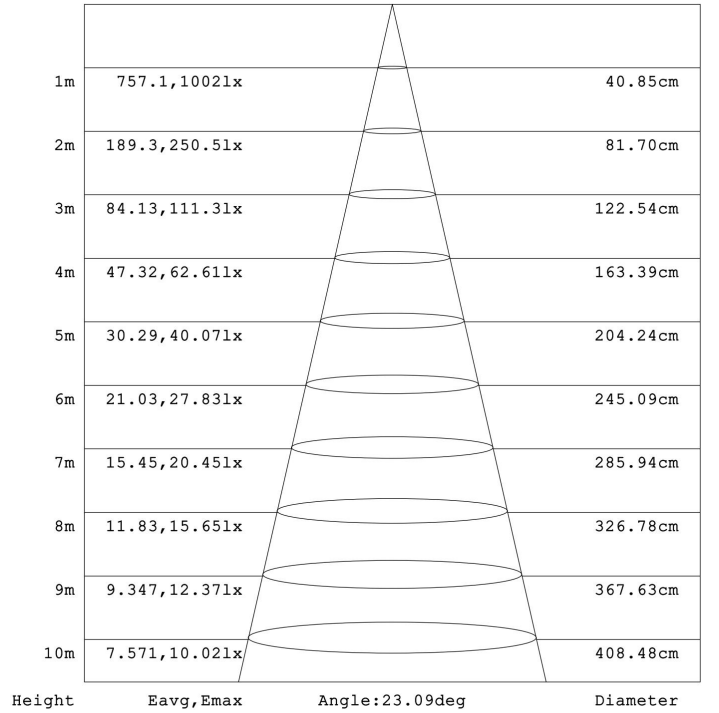

Note: The Curves indicate the illuminated area and the average illumination when the luminaire is at different distance.

LUMINANCE LIMITATION CURVES

GLARE	CLASS	ILLUMINANCE (lx)							
		2000	1000	500	<=300				
1.15	A								
1.50	B								
1.85	C								
2.20	D								
2.55	E								

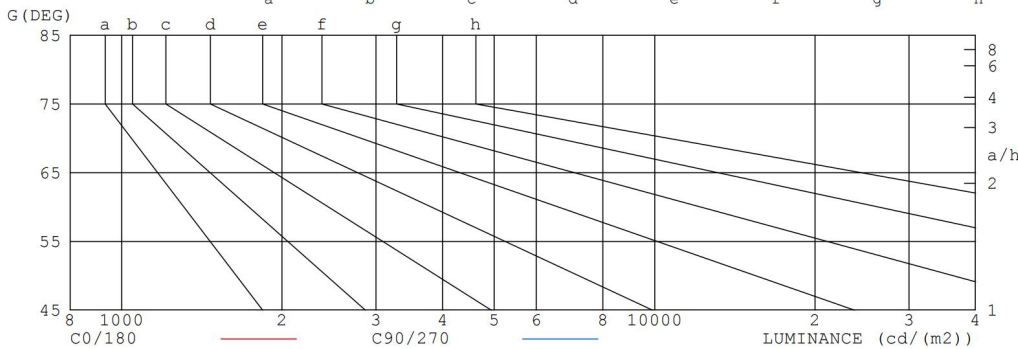

LUMINANCE cd/(m2)		
G (DEG)	C0/180	C90/270
85	27	2
80	20	6
75	16	12
70	19	18
65	23	25
60	28	34
55	40	45
50	66	59
45	104	77

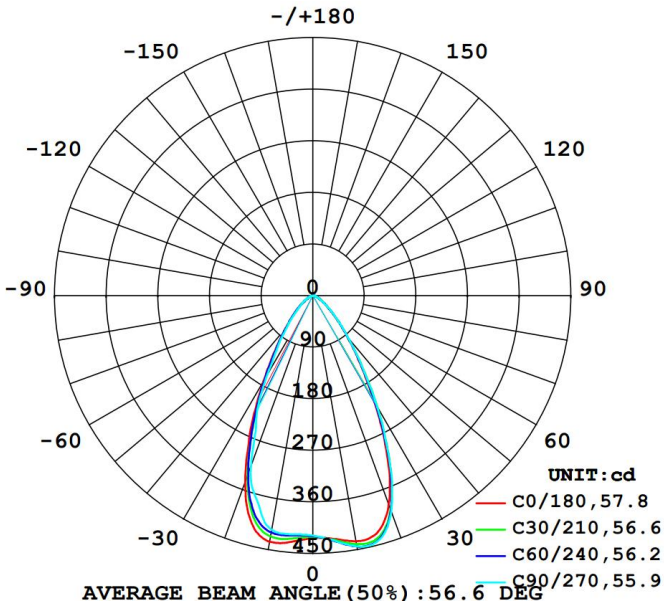

Flux out: 260.5 lm

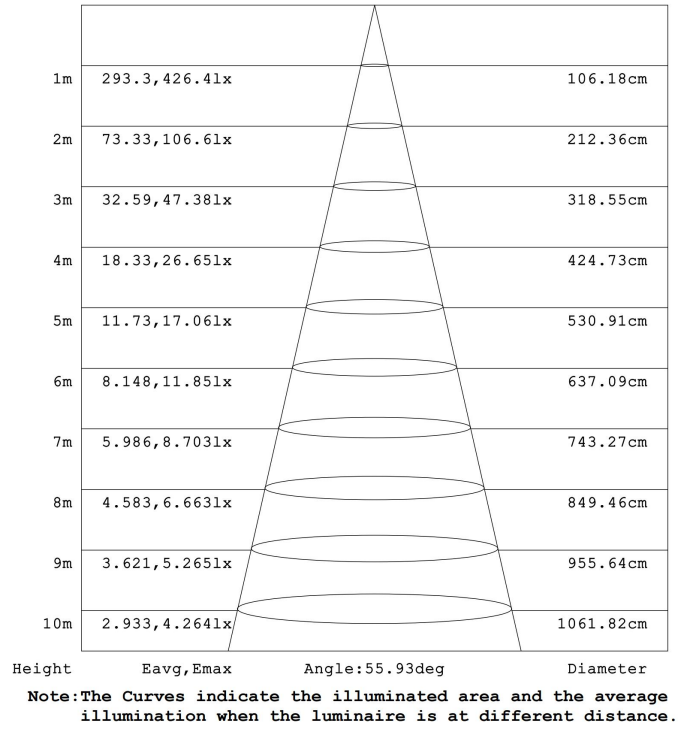

LUMINANCE LIMITATION CURVES

GLARE	CLASS	ILLUMINANCE (lx)							
1.15	A	2000	1000	500	<=300				
1.50	B		2000	1000	500	<=300			
1.85	C			2000	1000	500	<=300		
2.20	D				2000	1000	500	<=300	
2.55	E					2000	1000	500	<=300

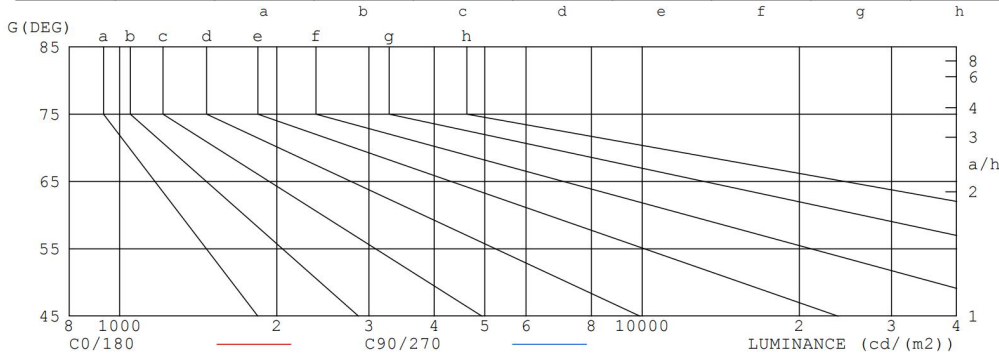

LUMINANCE cd/ (m2)		
G (DEG)	C0/180	C90/270
85	19	4
80	16	8
75	20	15
70	26	22
65	33	30
60	43	42
55	57	57
50	78	79
45	108	111

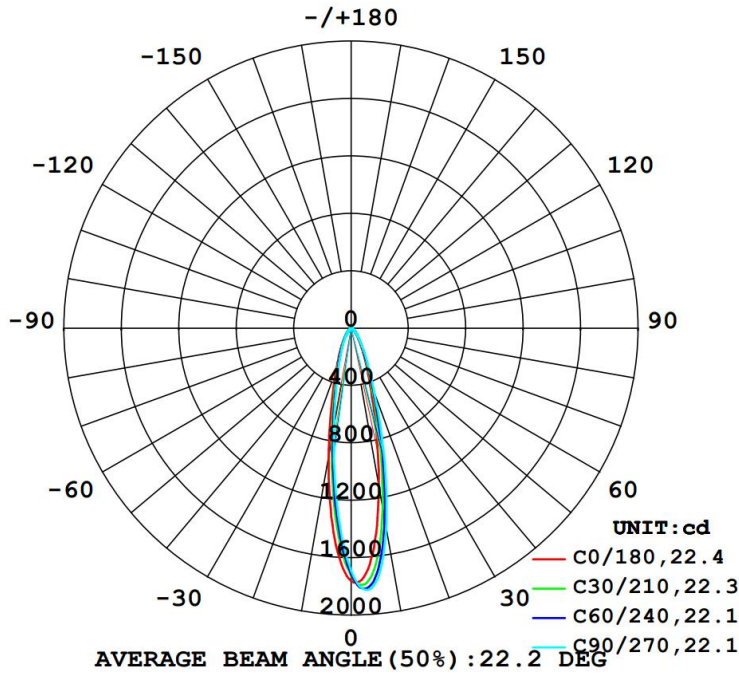

Flux out: 157.2 lm

1m	1209,1817lx	39.12cm
2m	302.2,454.2lx	78.25cm
3m	134.3,201.9lx	117.37cm
4m	75.56,113.5lx	156.50cm
5m	48.36,72.67lx	195.62cm
6m	33.58,50.47lx	234.75cm
7m	24.67,37.08lx	273.87cm
8m	18.89,28.39lx	313.00cm
9m	14.93,22.43lx	352.12cm
10m	12.09,18.17lx	391.25cm

Height Eavg, Emax Angle: 22.14deg Diameter

Note: The Curves indicate the illuminated area and the average illumination when the luminaire is at different distance.

LUMINANCE LIMITATION CURVES

GLARE	CLASS	ILLUMINANCE (lx)							
1.15	A	2000	1000	500	<=300				
1.50	B		2000	1000	500	<=300			
1.85	C			2000	1000	500	<=300		
2.20	D				2000	1000	500	<=300	
2.55	E					2000	1000	500	<=300

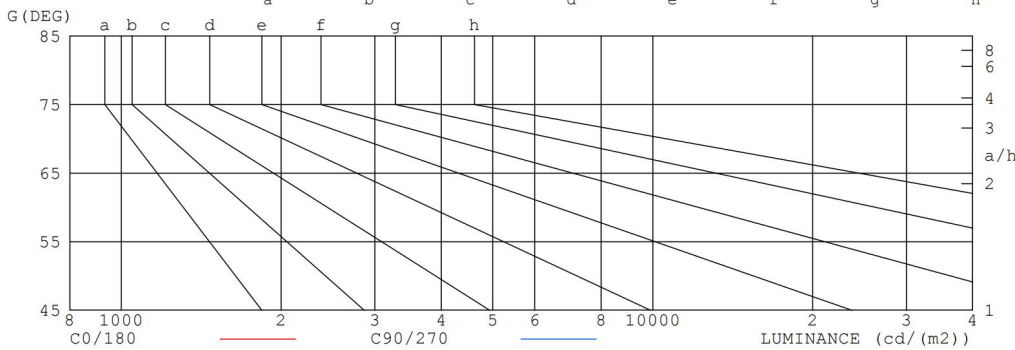

LUMINANCE cd/(m2)		
G (DEG)	C0/180	C90/270
85	31	2
80	22	5
75	18	9
70	18	14
65	21	19
60	26	27
55	35	39
50	49	57
45	70	83

ANTI-GLARE ACCESSORIES (Order Separately)

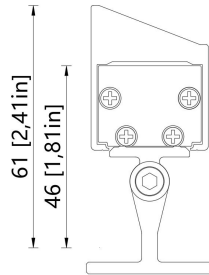

Characteristic analysis:

-Preferred application scenarios for anti-glare grills: If your wall washer lights are installed in places that require strict control of light pollution and create a-end lighting environment, such as hotel lobbies, art galleries, and the exterior walls of boutique shops, especially when the fixtures are installed at heights where people's line sight is likely to be directly above (such as the ceiling of a corridor, the facade of a low-rise building), anti-glare grills are a more reliable. It ensures that no matter how you adjust the bracket angle, the light is strictly constrained to the wall, avoiding new glare after adjusting the angle

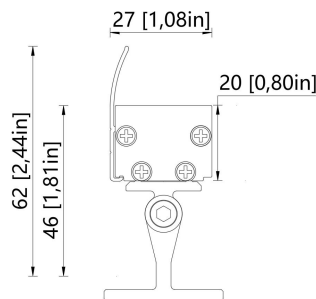

Characteristic analysis:

-The application of the anti-glare screen: If the project budget is limited, or the luminaire is mainly used to outline the contour of the top, illuminate the higher building facade (far above the line of sight of the human eye), or for the functional lighting of the landscape garden, then the anti-glare screen is a more cost-effective solution. It can effectively solve the most important side glare problem, and the installation is also simpler.

Product splicing schematic diagram

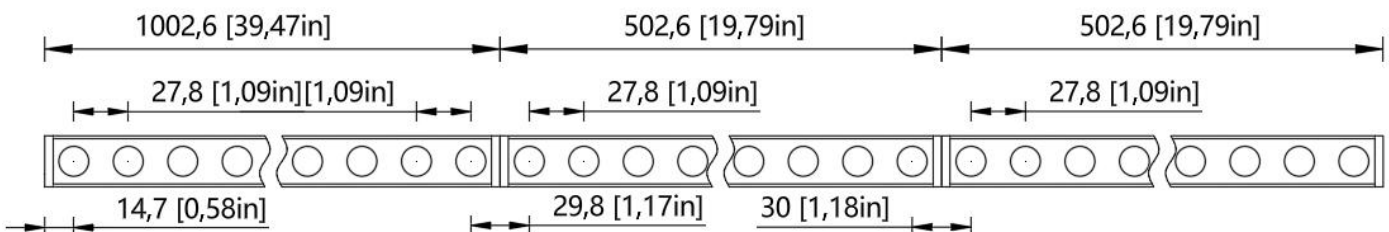

Installation Options

CA11D26.11.P11 (U stainless steel buckle-Low model)

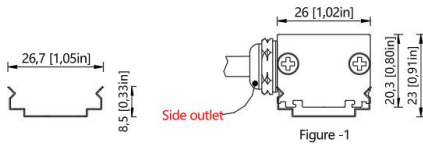

Characteristic analysis:

Advantages: simple structure, low cost, quick installation (usually a wall washer), simple appearance and corrosion resistance of stainless steel.

Common style: mostly flat-bottomed, fixed on the wall with screws, and the lamp body is directly clamped or buckled.

⚠ Note: If you choose this mounting buckle, you need to reserve a space for outgoing lines at the bottom. If there is no space, you can choose to go out at the side (as shown in Figure -1).

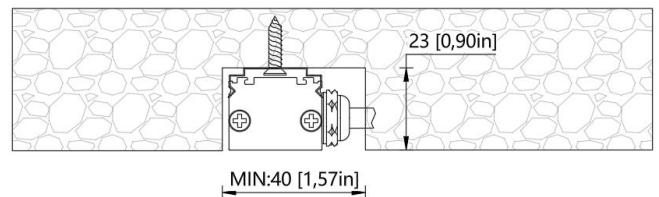

CA11D26.11.P12 (U stainless steel buckle-high model)

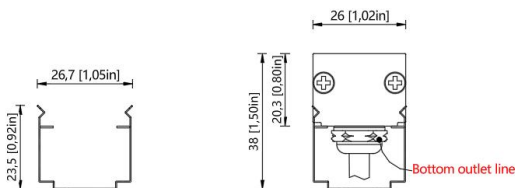

Advantages: simple structure, low cost, quick installation (usually a wall washer), simple appearance and corrosion resistance of stainless steel.

Common style: mostly flat-bottomed, fixed on the wall with screws, and the lamp body is directly clamped or buckled.

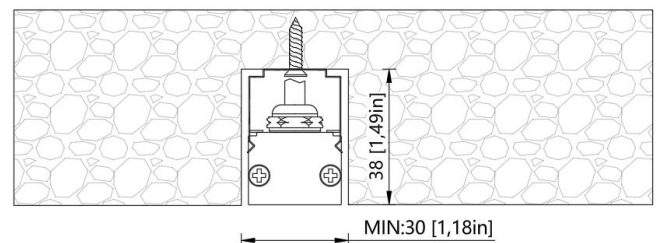

CA11D26.11.P13
Rotating aluminum bracket

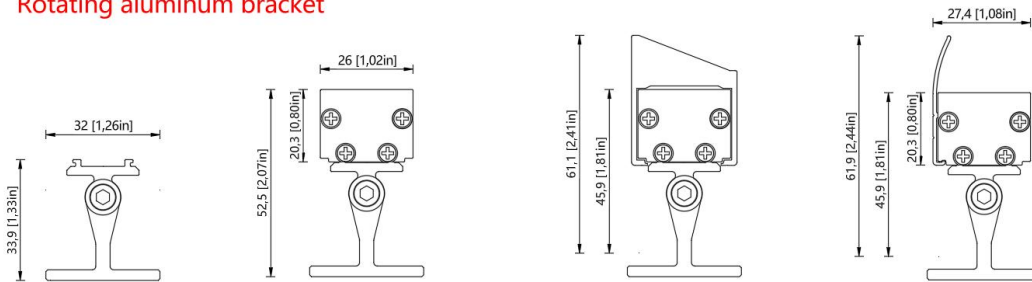

Characteristic analysis:

-Advantages: the core advantage is "universal adjustment", which has the adjustable range in horizontal and vertical directions (usually 15 ~ 30) and has strong adaptability. Aluminum is light and corrosion-resistant.

-The installation surface and the illuminated wall surface are not in the same plane, and there are obstacles in the middle or gaps need to be crossed.

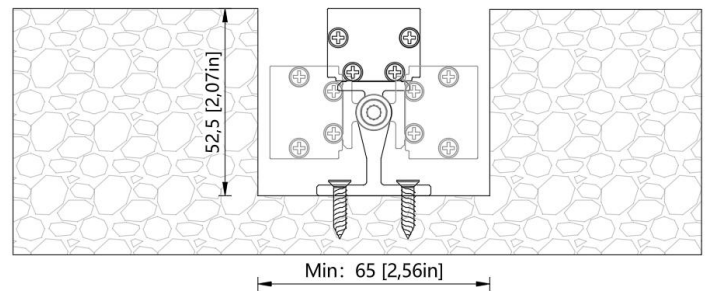

CA11D26.11.P14
(Simple rotary aluminum bracket)

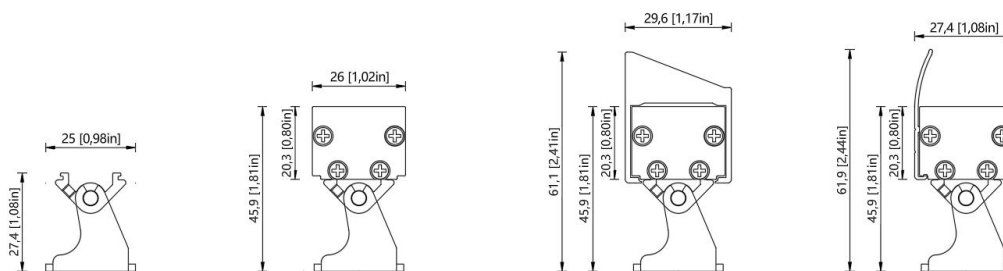

Characteristic analysis:

-Advantages: the core advantage is "universal adjustment", which has the adjustable range in horizontal and vertical directions (usually 15 ~ 30) and has strong adaptability. Aluminum is light and corrosion-resistant.

-The installation surface and the illuminated wall surface are not in the same plane, and there are obstacles in the middle or gaps need to be crossed.

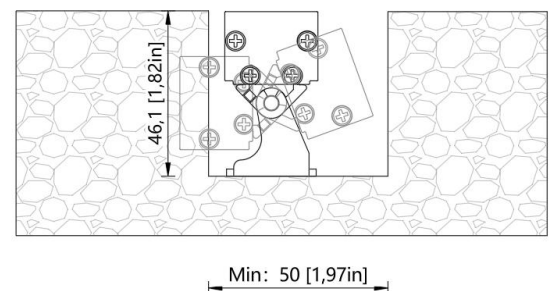

0/1-10V Lamp Power Supply/Dimmer Connection Description

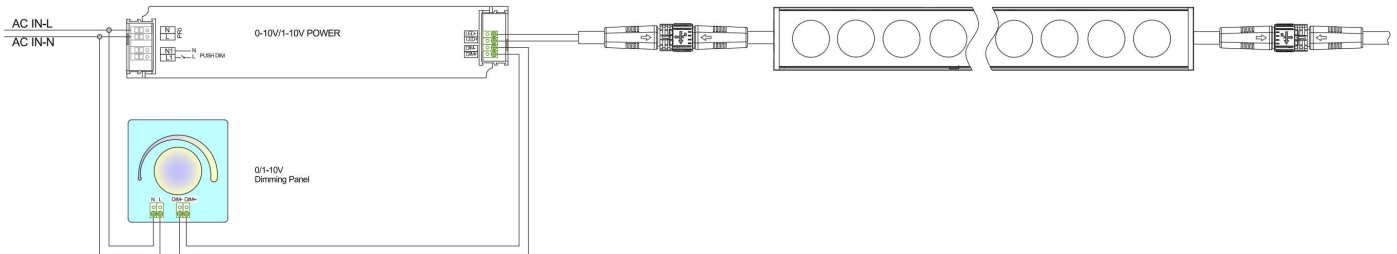

1. The signal line is separated from the power line

It is absolutely forbidden to arrange the dimming signal line (V+/-) and the AC power line (L/N) in the same conduit or trunking, nor to use the same set of multi-core cables. The electromagnetic interference of AC power supply will seriously interfere with the weak 0-10V DC signal, resulting in flickering, jitter or uneven dimming of lights.

Best practice: Using shielded twisted pair as dimming light and grounding the shielding layer at one end of the driver can effectively suppress interference.

2. Distinguish between 0-10V and 1-10V:

When buying drives and controllers, you need to confirm their specifications. They can be used together, but their behaviors are different:

1-10V controller +0-10V driver: When the dimming knob is adjusted to the lowest level, the voltage is 1V, and the lamp will not be completely turned off, and it will remain about 10% dim.

When the dimming knob is adjusted to the lowest voltage, the driver will judge that the signal is lost, and the lamp 0-10V controller +1-10V driver: may be completely turned off or flicker.

. When designing, if "off to off" is needed, 1-10V system should be selected.

3. Load capacity and wiring distance:

The output channel of each dimming controller has the maximum load capacity (for example, the minimum load current is 0.1mA and the maximum load current is 2mA). How many drivers can a controller take depends on whether the sum of the input currents of all drivers' DIM ports can exceed the controller capacity. The signal line should not be too long, and it is recommended not to exceed 50 meters. Too long will lead to line voltage drop, so that the actual voltage reaching the driver is lower than the output voltage of the controller, which will affect the dimming consistency.

4. Common ground problem

In some complex systems, if the DIM- terminal potentials of multiple drivers are inconsistent, it may cause interference. This problem can be avoided by ensuring that all signal loops use the dimming controller with isolation function well.

5. Power-on sequence:

The system should follow the correct power-on sequence: first turn on the main power supply, so that the driver and controller can get power, and then perform dimming operation. A sudden full voltage signal may impact the driver.

6. Compatibility and testing:

Different brands of drives and controllers may have subtle compatibility problems. Before the installation of large-scale projects, samples must be tested and inspected. Prove the smoothness, minimum brightness and flicker of dimming curve.

Wiring diagram of DALI digital lighting system

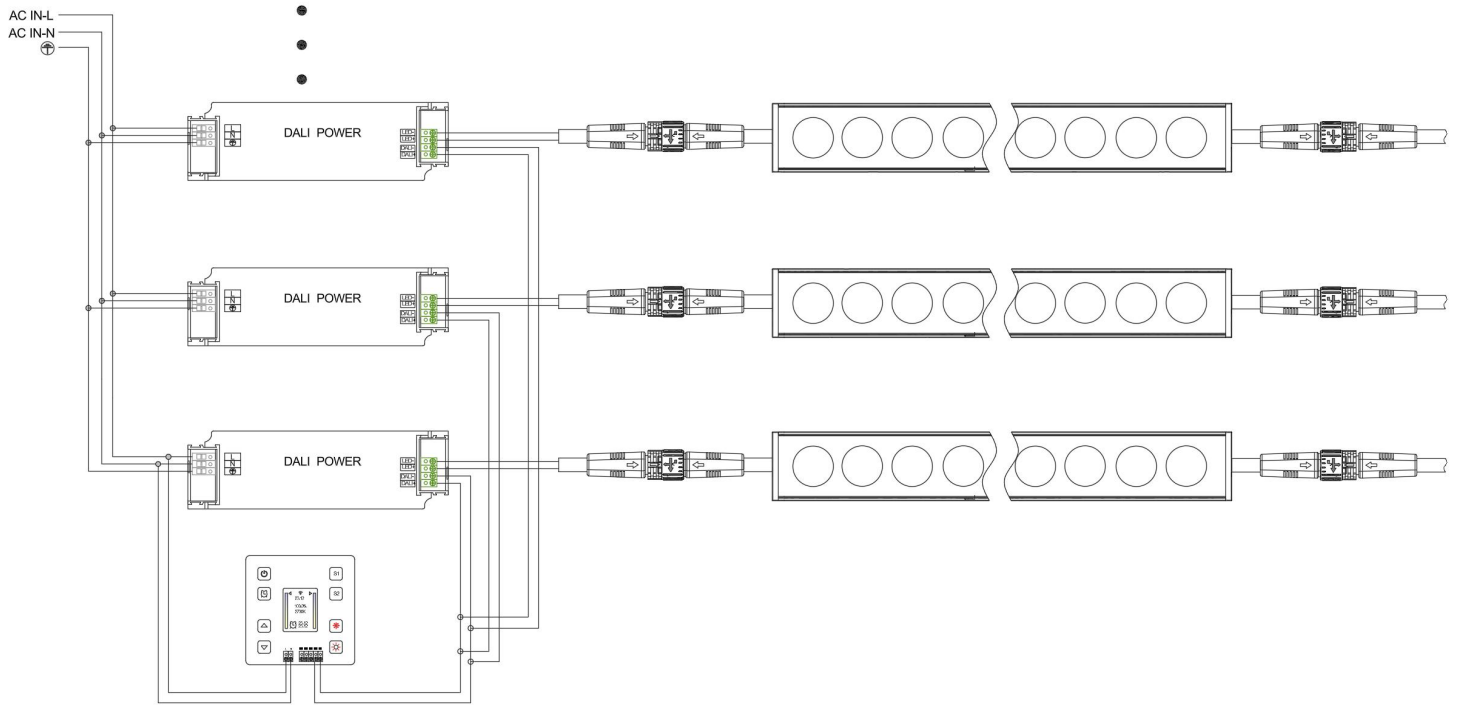

1. Laying bus: use twisted pair to connect DALI+ and DALI- terminals of all equipment (well connection).
2. Connect the power supply: Connect the only DALI system power supply to the bus.
3. Access control: connect the controller, panel and sensor to the bus.
4. Connect the driver with the load: connect the AC power supply (L,N) and DALI bus for each driver, and connect the lamps with its output.
5. Power-on debugging: Use DALI debugging software to allocate short url for each device, and group and set the scene.