

Model No : CA11D72.11

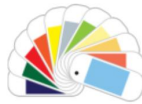

Features:

- Seamless Look -Wide 72mm Design .
- Long-Throw Optics: Illuminates up to 100m.
- RGBW + DMX512 — Rich Color & Precision Control .
- Rated IP66 — Withstands Harsh Environments.
- Multi-Angle Mount — Fits Any Surface & Angle.



Normal/RAL series:9002/9006/9011
Custom Colour &Finish

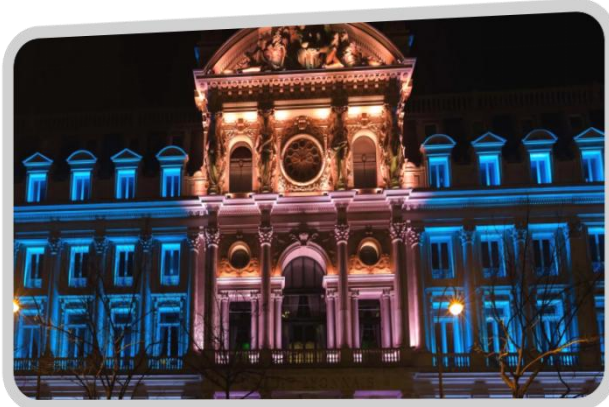

Application:

- It's widely used as a decorative lights, and use it as the lights;
- Stage decoration, festival, exhibition, wedding;
- Backlight of signage, channel letters lighting;
- Landscape layout lighting;

Dimensions (Line Voltage) :

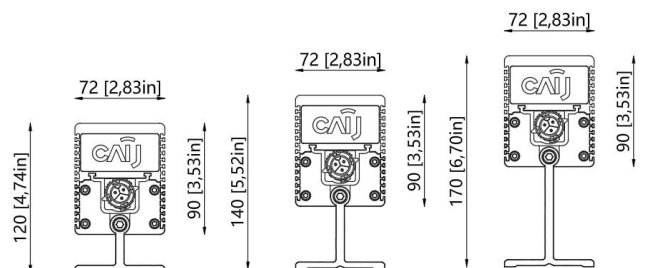
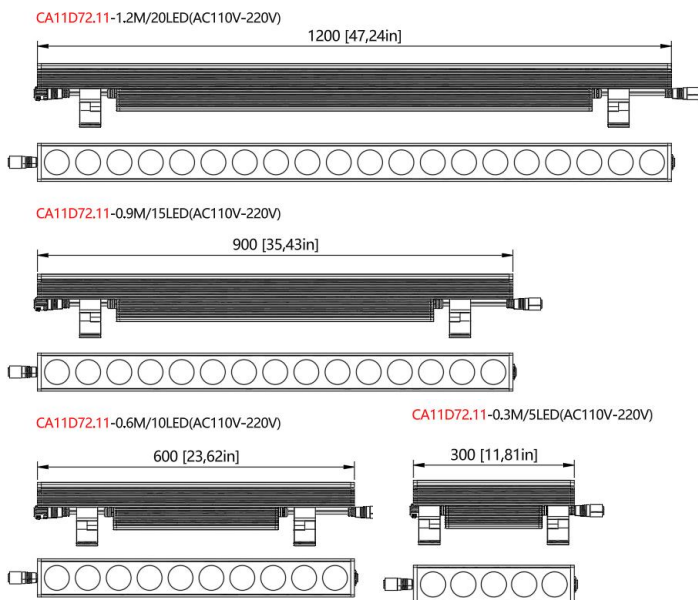

Physical

Housing Material	6063 AviationGrade Aluminum
Lens Material	Tempered glass
End Cap Material	Die cast aluminium
Gasket Material	Silicone
Surface Finish	primer and electrostatically-applied, powder coat paint finish

Electrical and Control

Voltage	DC 24V / AC 220V
Wattage	Max 100W/M
Control	0-10V / DMX / DALI /ON /OFF
Inrush Current (Peak)	Meets NEMA-410 requirements (Based on voltage and control specifications, consult factory for details)

Environmental

Storage Temperature	-40 °C to 85 °C
Start-up Temperature	-40 °C to 50 °C
Operating Temperature	For 32.8 W/m fixtures: -40 °C to 50 °C For 72.18 W/m fixtures, CE Certification: -40 °C to 40 °C
Ingress Protection Rating	IP40 IP66 (It can prevent the low-pressure jet water from invading from any direction, but it does not mean it can be soaked in water for a long time) .For details please consult the factory
Impact Resistance Rating	IK08 (Consult factory for IK08 lens option)

Accessories (Order Separately)

Cables	Lumenfacade Leader Cable Lumenfacade Jumper Cable Lumenfacade T-Junction
--------	--

Distribution Curve Flux

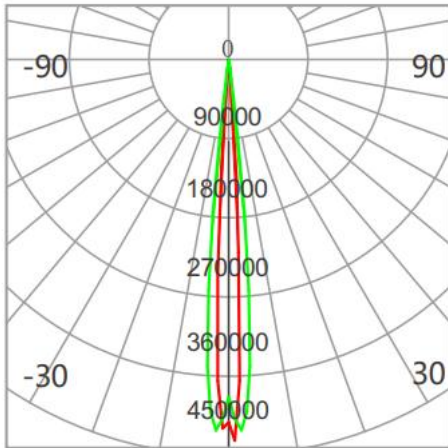

Average Beam Angle(50%):8.7 DEG
Beam angle:9°

ANTI-GLARE ACCESSORIES (Order Separately)

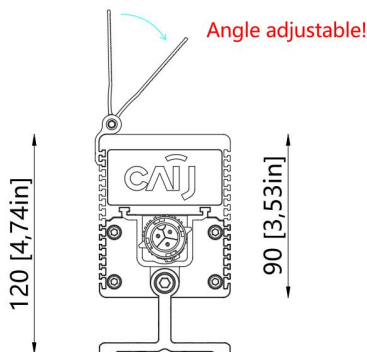

Characteristic analysis:

-Preferred application scenarios for anti-glare grills: If your wall washer lights are installed in places that require strict control of light pollution and create a end lighting environment, such as hotel lobbies, art galleries, and the exterior walls of boutique shops, especially when the fixtures are installed at heights where people's line sight is likely to be directly above (such as the ceiling of a corridor, the facade of a low-rise building), anti-glare grills are a more reliable. It ensures that no matter how you adjust the bracket angle, the light is strictly constrained to the wall, avoiding new glare after adjusting the angle

Characteristic analysis:

-The application of the anti-glare screen: If the project budget is limited, or the luminaire is mainly used to outline the contour of the top, illuminate the higher building facade (far above the line of sight of the human eye), or for the functional lighting of the landscape garden, then the anti-are screen is a more cost-effective solution. It can effectively solve the most important side glare problem, and the installation is also simpler.

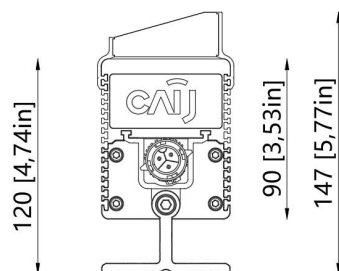

Installation method

CA11D72.11.P57

(Rotating aluminum bracket (low model))

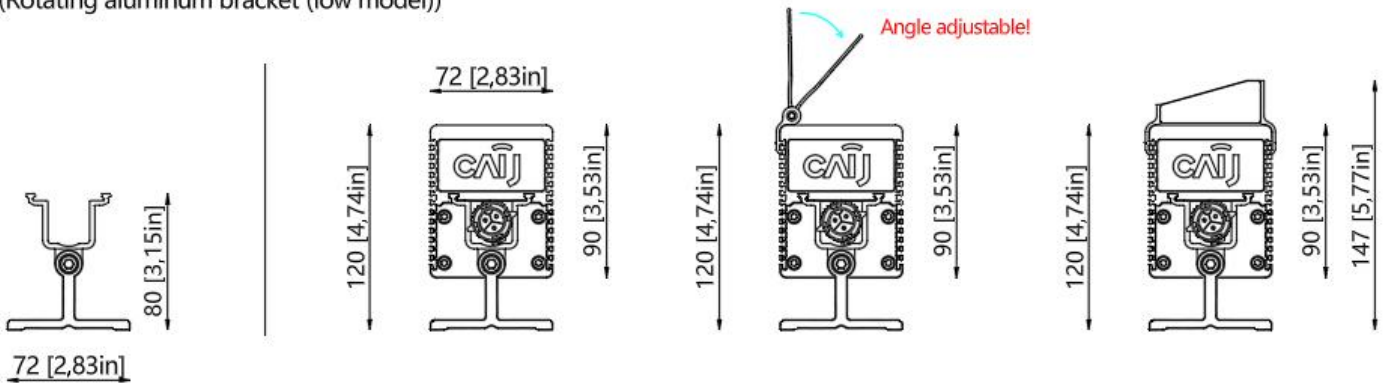

Characteristic analysis:

-Advantages: simple structure, low cost, quick installation (usually with slot wall washing lamp), simple appearance and corrosion-resistance of stainless steel.

Common styles: mostly flat base, fixed on the wall with screws, and the lamp body is directly clamped or buckled.

CA11D72.11.P58

(Rotating aluminum bracket (medium model))

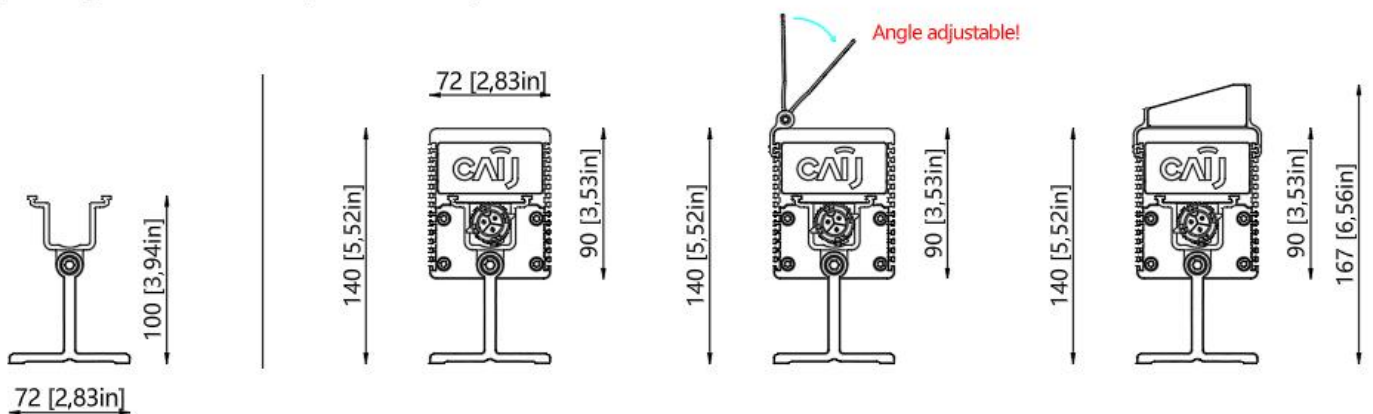

Characteristic analysis:

-Advantages: the core advantage is "universal adjustment", which has the adjustable range in horizontal and vertical directions (usually 15 ~ 30) and has strong adaptability. Aluminum is light and corrosion-resistant.

-The installation surface and the illuminated wall surface are not in the same plane, and there are obstacles in the middle or gaps need to be crossed.

CA11D72.11.P59
(Rotating aluminum bracket (high model))

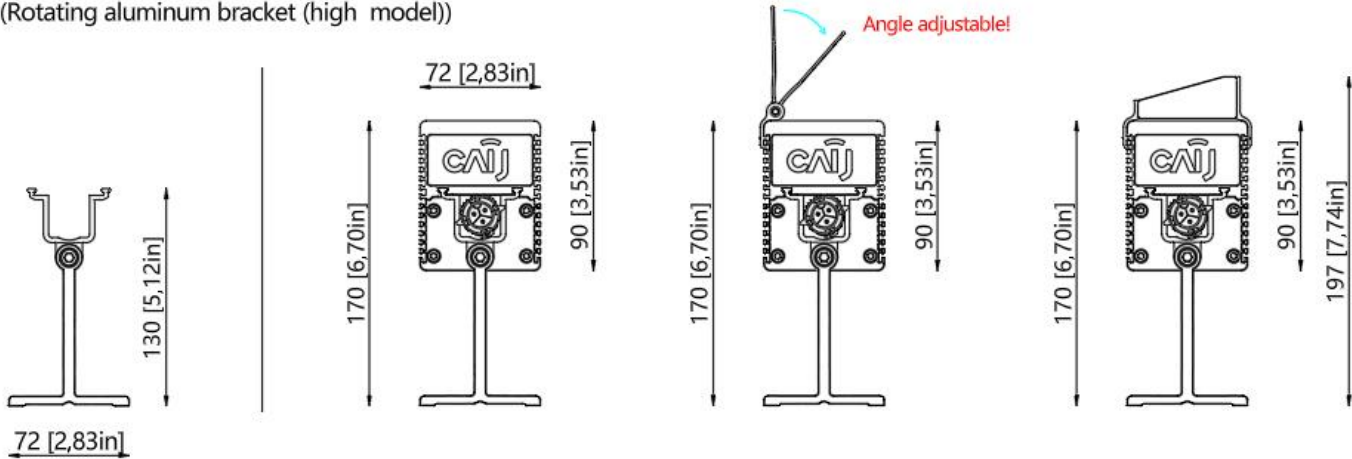

Characteristic analysis:

- Advantages: the core advantage is "universal adjustment", which has the adjustable range in horizontal and vertical directions (usually 15 ~ 30) and has strong adaptability. Aluminum is light and corrosion-resistant.
- The installation surface and the illuminated wall surface are not in the same plane, and there are obstacles in the middle or gaps need to be crossed.

Installation instructions

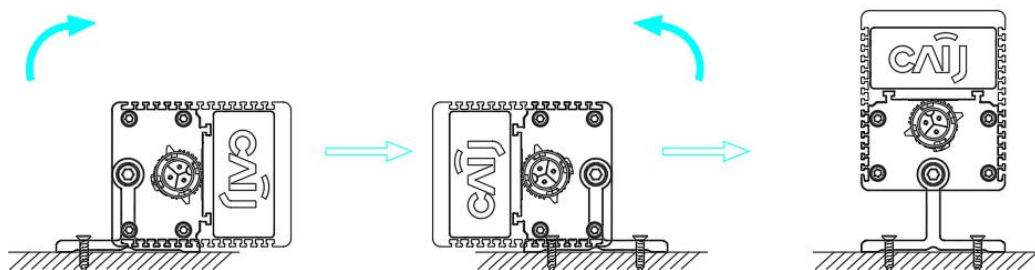

0/1-10V Lamp Power Supply/Dimmer Connection Description

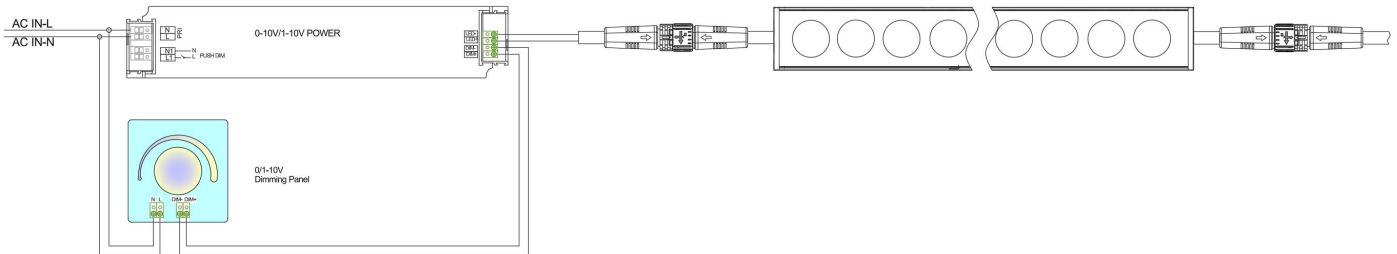

1. The signal line is separated from the power line

It is absolutely forbidden to arrange the dimming signal line (V+/-) and the AC power line (L/N) in the same conduit or trunking, nor to use the same set of multi-core cables. The electromagnetic interference of AC power supply will seriously interfere with the weak 0-10V DC signal, resulting in flickering, jitter or uneven dimming of lights.

Best practice: Using shielded twisted pair as dimming light and grounding the shielding layer at one end of the driver can effectively suppress interference.

2. Distinguish between 0-10V and 1-10V:

When buying drives and controllers, you need to confirm their specifications. They can be used together, but their behaviors are different:

1-10V controller +0-10V driver: When the dimming knob is adjusted to the lowest level, the voltage is 1V, and the lamp will not be completely turned off, and it will remain about 10% dim.

When the dimming knob is adjusted to the lowest voltage, the driver will judge that the signal is lost, and the lamp 0-10V controller +1-10V driver: may be completely turned off or flicker.

. When designing, if "off to off" is needed, 1-10V system should be selected.

3. Load capacity and wiring distance:

The output channel of each dimming controller has the maximum load capacity (for example, the minimum load current is 0.1mA and the maximum load current is 2mA). How many drivers can a controller take depends on whether the sum of the input currents of all drivers' DIM ports can exceed the controller capacity. The signal line should not be too long, and it is recommended not to exceed 50 meters. Too long will lead to line voltage drop, so that the actual voltage reaching the driver is lower than the output voltage of the controller, which will affect the dimming consistency.

4. Common ground problem

In some complex systems, if the DIM- terminal potentials of multiple drivers are inconsistent, it may cause interference. This problem can be avoided by ensuring that all signal loops use the dimming controller with isolation function well.

5. Power-on sequence:

The system should follow the correct power-on sequence: first turn on the main power supply, so that the driver and controller can get power, and then perform dimming operation. A sudden full voltage signal may impact the driver.

6. Compatibility and testing:

Different brands of drives and controllers may have subtle compatibility problems. Before the installation of large-scale projects, samples must be tested and inspected. Prove the smoothness, minimum brightness and flicker of dimming curve.

Wiring diagram of DALI digital lighting system

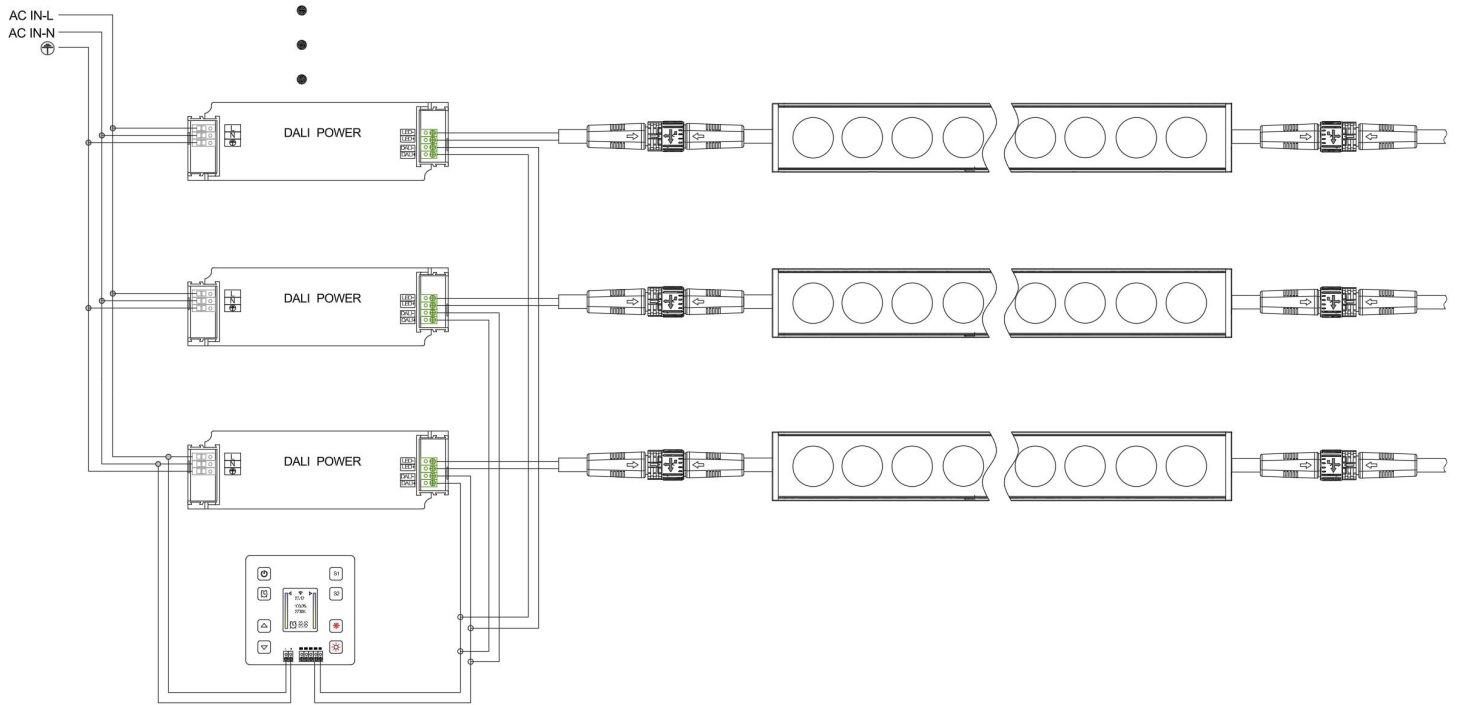

1. Laying bus: use twisted pair to connect DALI+ and DALI- terminals of all equipment (well connection).
2. Connect the power supply: Connect the only DALI system power supply to the bus.
3. Access control: connect the controller, panel and sensor to the bus.
4. Connect the driver with the load: connect the AC power supply (L,N) and DALI bus for each driver, and connect the lamps with its output.
5. Power-on debugging: Use DALI debugging software to allocate short url for each device, and group and set the scene.